

CITY OF SHAWNEE, KANSAS

Codes Administration Newsletter

January 7, 2009

913-742-6010

<http://www.cityofshawnee.org/Codes/codes.html>

NEW PHONE NUMBERS

The Shawnee Codes Administration office is getting new phone numbers. You can now dial the Codes Administration office directly by calling 913-742-6010. The old extensions within City Hall will be turned off at the end of February, 2009. You can still reach us after February by calling the 913-631-2500 number, and then by choosing option 9, then dialing 6010.

2006 CODES UPDATE

The City of Shawnee City Council approved the adoption of the following construction codes:

- 2006 International Building Code,
- 2006 International Residential Code,
- 2006 International Plumbing Code,
- 2006 International Mechanical Code,
- 2006 International Fuel Gas Code,
- 2006 International Energy Conservation Code,
- 2005 National Electrical Code.

These codes will be effective for any permit issued on or after **April 1, 2009**. Copies of the adopting ordinances and a summary of amendments can be found at <http://www.cityofshawnee.org/Codes/codes.html>.

NEW INSPECTION REQUIRED FOR WATER RESISTIVE BARRIERS

Section R703.2 of the 2006 International Residential Code (IRC) was amended to require that a Water Resistive Barrier (**WRB**) be installed on studs or sheathing on all wood frame exterior walls, including walls with paperbacked stucco lath. One layer of #15 asphalt felt complying with ASTM D226 or other approved material such as a house wrap is required to meet this code requirement. **An inspection of this item is required.**

The inspector will be checking to see that the material is installed properly, that the material is free of holes and breaks, properly integrated into required flashing, and that the material is properly wrapped around corners. This inspection is required on all exterior wood framed walls that will be covered with **stucco, EIFS, or masonry veneer**. Inspection requests should be placed at least 24 hours before the inspection is needed.

Please note that a **WRB** is required behind paperbacked stucco lath. This new required inspection is to be done before the paperbacked stucco lath is applied.

FLASHING AMENDMENT TO THE 2006 IRC

The City of Shawnee has adopted an amendment to the 2006 International Residential Code that requires rough opening flashing to be installed in a specific manner for all door and window rough openings in wood frame construction. This requirement will be effective for any project permitted on or after **April 1, 2009**.

Flashing installed as required by the amendment should allow an inspector to verify the rough opening sill flashing has been installed at the time of rough-in inspection. The text of the amendment reads as follows:

Sill Flashing or Pan Flashing, for the purposes of this section, shall mean a type of flashing used at the base of a rough opening to divert incidental water to the exterior, or to the exterior surface of a concealed Water Resistive Barrier (WRB). Sill or pan flashings have upturned legs at the interior edge and ends of the rough opening to form a three-sided pan. They are intended to collect and drain water toward the exterior, including water that may enter through a window or door unit.

All rough openings for windows and doors shall be flashed in the following manner. An approved water-resistive barrier shall first be installed on the wall, covering the rough opening. The water resistive barrier (WRB) over the rough opening shall then be cut in the “modified I” or “standard I” fashion, and the side and bottom flaps formed by the cut shall be folded into the rough opening, and secured so that they remain visible on the interior side of the framing until the rough framing inspection has been approved. The water-resistive barrier (WRB) flaps shall remain visible on the interior side of the framing until the rough framing inspection has been approved.

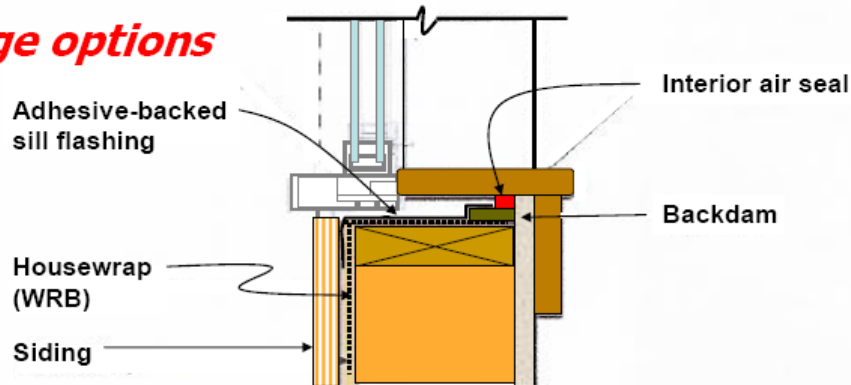

Figure 1. Modified I cut

The base of every rough window or door opening shall be provided with positive slope toward the exterior, or shall be provided with an approved mechanism to prevent water from escaping to the interior side of the opening, such as a dam strip, factory bevel, or approved equal.

Single Wall Construction

Sill drainage options



A strip of wood nailed at the back of the rough opening sill forms a dam to prevent water from draining into the interior

Windows installed under siding, over WRB

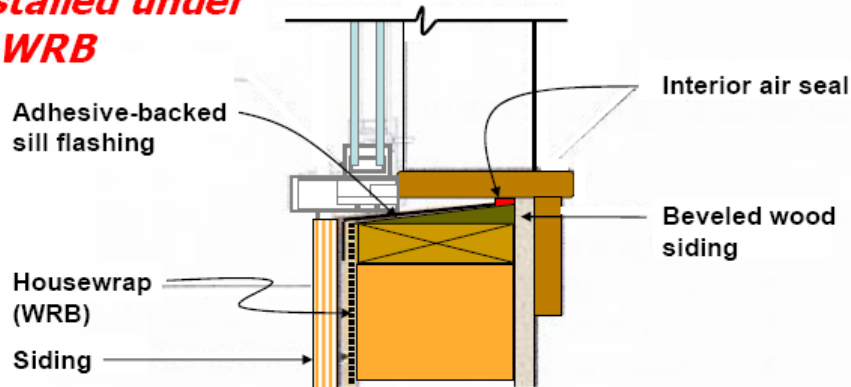

A piece of wood bevel siding nailed over the sill to create positive drainage toward the exterior is even better

Figure 2. Rough opening sill flashing detail

Sill flashing or pan flashing shall be provided at the base of every rough opening for windows or doors. A continuous length of approved self-adhering flexible flashing shall be installed as the sill flashing. The self-adhering flexible flashing material shall comply with AAMA 711-05, Voluntary Specification for Self-Adhering Flashing Used for Installation of Exterior Wall Fenestration Products, published by the American Architectural Manufacturers Association, or other approved standards. A preformed metal or plastic pan flashing assembly may be substituted for the flexible flashing when approved by the Building Official.

The self-adhering flexible flashing material and the preformed metal or plastic pan flashing assembly shall be installed in compliance with the manufacturer's installation instructions. The self-adhering flexible flashing material shall be not less than 7 inches (7") wide for walls constructed with 2 X 4 studs, and not less than 9 inches (9") wide for walls constructed with 2 X 6 studs. Sill flashing shall extend up the sides of the rough opening not less than six inches (6") above the rough opening sill. The sill flashing shall extend to the exterior surface of the approved water-resistive barrier, and shall cover the entire rough opening sill. A permanent drainage mechanism for the sill shall be provided so that the sill drains to the approved water-resistive barrier. All sill flashing or pan flashing shall remain visible on the interior side of the framing until the rough framing inspection has been approved. Alternate Sill Flashing or Pan Flashing methods, other than those described above may be substituted when first approved by the Building Official.

Additional information on sill flashing can be obtained at the following Johnson County website (Window Installation Guidelines):

<http://jocobo.jocogov.org/ConstructionStandards/Johnson%20County%20Guide%20to%20Window%20Installation%20WEB.pdf>

Windows and door installation must also comply with the manufacturer's installation requirements. Please contact Steve Thompson at 913-742-6010, or by e-mail at sthompson@ci.shawnee.ks.us if you have any questions, or would like additional information.

SUBCONTRACTOR VERIFICATION

Our office will begin requiring written verification of the names of the subcontractors who performed electrical, plumbing, fire protection, or mechanical work on new building construction projects, or substantial remodeling projects, beginning **April 1, 2009**. The written verification of the subcontractor work shall be on an approved form, submitted by the subcontractor after the work is performed, and must be provided to our office before a final inspection can be completed.

This regulation is intended to provide verification that Johnson County licensed subcontractors have been used on construction projects, as required by the County licensing rules, and that subcontractors have a valid city business license. General contractors found to be using unlicensed subcontractors will be brought to the attention of the County. Subcontractors may make copies of an original notarized form and submit a copy for each project as long as the original form is less than one year old. Forms may be obtained at our office, or can be found at the website listed at the beginning of this newsletter.

PROJECT VALUE INCREASE

Permit fees are based on project value, and project valuation is set by the building official. Based on new valuation data, the value used for new single family dwelling will be

increased from \$60.00 to \$80.00 per square foot of finished area, and from \$10.00 to \$20.00 per square foot of area for unfinished basements, garages, and decks, effective **April 1, 2009**.

2006 IRC FOUNDATION WALL REQUIREMENTS

The 2006 International Residential Code (IRC) Section R404 has significant revisions to the requirements for the construction of concrete foundation walls, including requiring use of 60 #/cubic foot as the equivalent fluid pressure for soil types in Shawnee, anchor bolt spacing at 7" on center and anchor clips for floor joists to provide top of wall restraint, and significant increases in required reinforcing steel.

The IRC also allows foundation walls to be constructed based on design using ACI 318-05, or ACI 332-05, or other approved structural standards. The City of Shawnee accepts the "Residential Foundation Guideline" published by Johnson County as an approved structural standard. This guideline is available at the Codes Administration offices, or can be found at the following Johnson County website:

<http://jocobo.jocogov.org/Standards.htm>

Contractors choosing not to use the prescriptive requirements found in the Residential Foundation Guideline, or those found in Chapter 4 of the IRC, may submit plans prepared by a KS registered design professional. Those plans should include foundation design details, top of wall restraint details, and structural calculations. A site specific soil test, conducted by an approved agency, using an approved method, will be required for designs that use less than 60 #/cubic foot as the equivalent fluid design pressure.

LAND DISTURBANCE PERMITS AND BONDS

The Shawnee City Council adopted a new land disturbance ordinance (http://www.cityofshawnee.org/swm/pdf/ord_land_disturbance.pdf) in October of 2007 which affects most construction projects in the City of Shawnee. The new ordinance fulfills the City's compliance activity objectives to meet the EPA's National Pollutant Discharge Elimination System (NPDES) Phase II requirements.

A new Land Disturbance Permit (**LDP**) requirement was created by the ordinance, along with new bond requirements, new regulations, and new fees (http://www.cityofshawnee.org/swm/pdf/fees_land_disturbance.pdf).

The Codes Administration Division was recently assigned the responsibility for enforcement of the land disturbance permit requirements and regulations. The following is a summary of new requirements:

- A **Low Impact LDP** is required for the construction of any structure of 1000 square feet or more when less than 1 acre of ground will be disturbed.
- The **Low Impact LDP** fee is \$75.00.
- A new \$5000.00 **Low Impact LDP** bond will be required instead of the old mud bond. A new form is being prepared by staff and being reviewed by bonding companies, and should be available in February of 2009.

- A site specific “Sediment and Erosion Control Plan” is required as part of the **Low Impact LDP** application.
- All sediment and erosion control measures, including a gravel construction entrance, must be in place prior to excavation work. **Building inspections may be refused based on failure to maintain effective sediment and erosion control measures.**
- The **Low Impact LDP** permit holder is responsible to install, inspect, and maintain the construction site sediment and erosion control measures.
- Dirt, mud, or debris in the street or right of way still must be cleaned up within 4 hours of notification, or the City will clean up and bill permit holders.
- Notice to install, maintain or correct sediment and erosion control measures will provide a 3 day time limit to come into compliance. The City will install the measures after 3 days, and then bill permit holders if the measures have not been completed within the time limit.
- Projects that disturb one acre or more are required to obtain a **Standard LDP**. Permit fees are based on the area to be disturbed and the quantity of excavation or fill. The **Standard LDP** fee schedule can be found at the website listed at the beginning of this newsletter.
- Projects that require a **Standard LDP** are also required to submit a Storm Water Pollution Prevention Plan (**SWPPP**). The **SWPPP** and the Sediment and Erosion Control Plan are required to be prepared and sealed by a KS registered professional engineer or landscape architect.
- Projects that require a **Standard LDP** also require that the owner hire a Qualified Erosion Control Specialist (**QECS**). The **QECS** is responsible for inspecting, reporting, and maintaining the site in compliance with the **SWPPP** and the Sediment and Erosion Control Plan, among other responsibilities.

2009 CITY OF SHAWNEE HOLIDAYS

The Codes Administration offices will be closed on the following dates as official holidays in 2009:

- Thursday, January 1, 2009.....2009 New Year’s Day Holiday
- Monday, January 19, 2009.....Martin Luther King, Jr. Day
- Monday, February 16, 2009.....Presidents’ Day
- Monday, May 25, 2009.....Memorial Day
- Friday, July 3, 2009.....Independence Day
- Monday, September 7, 2009.....Labor Day
- Wednesday, November 11, 2009.....Veterans’ Day
- Thursday, November 26, 2009.....Thanksgiving Day
- Friday, November 27, 2009.....Thanksgiving Holiday
- Friday, December 25, 2009.....Christmas Holiday